

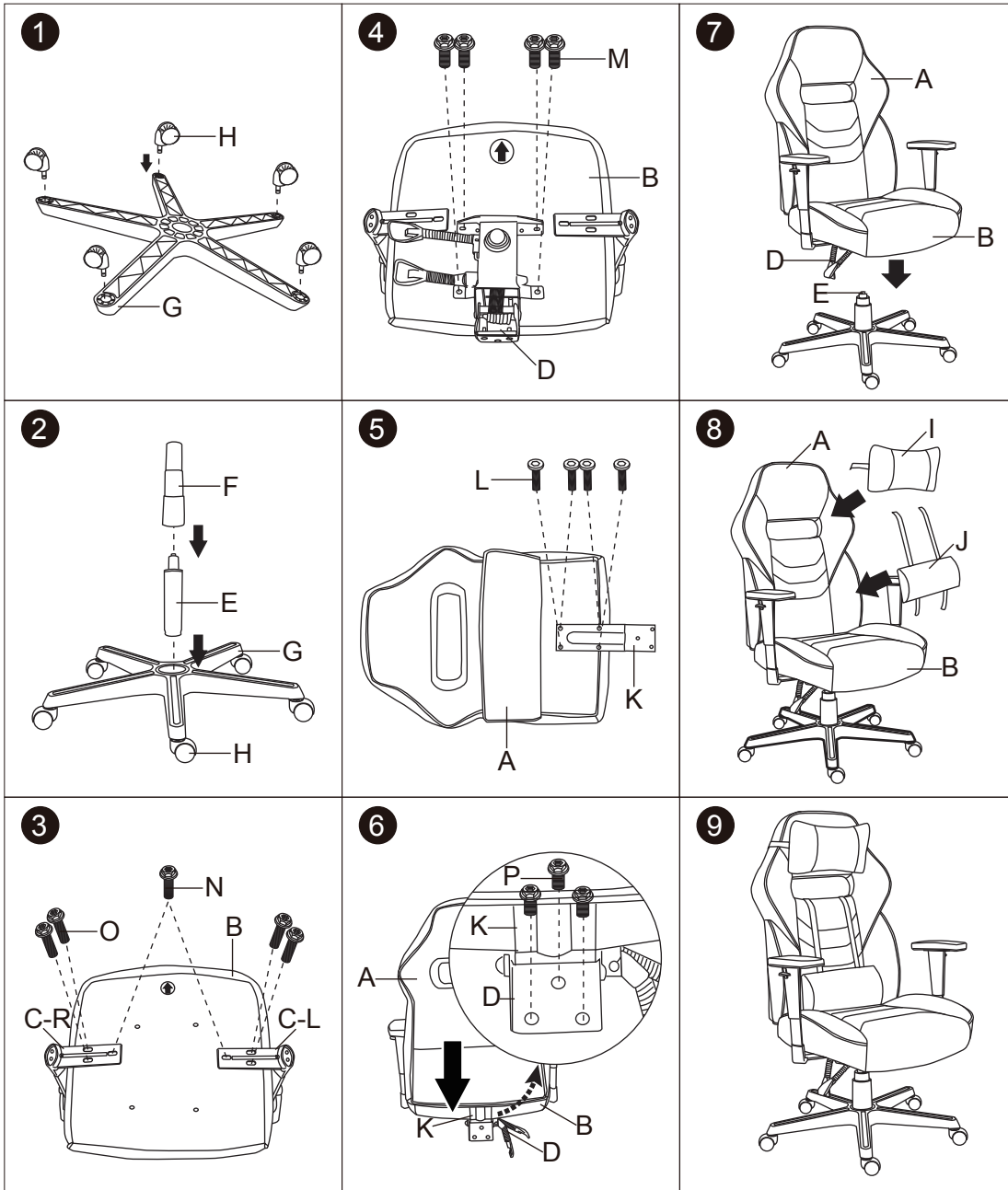









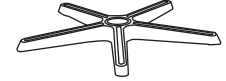





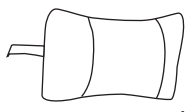

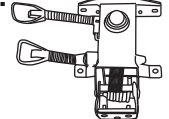
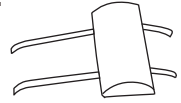
# ASSEMBLY INSTRUCTIONS

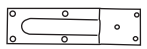

<b>A.</b>  1PC	<b>G.</b>  1PC	<b>M.</b>  4PCS
<b>B.</b>  1PC	<b>H.</b>  5PCS	<b>N.</b>  2PCS
<b>C(-L/-R).</b>  1PC	<b>I.</b>  1PC	<b>O.</b>  4PCS
<b>D.</b>  1PC	<b>J.</b>  1PC	<b>P.</b>  3PCS
<b>E.</b>  1PC	<b>K.</b>  1PC	<b>Q.</b>  1PC
<b>F.</b>  1PC	<b>L.</b>  4PCS	

Model: ALE-GM4136/ALE-GM4146  
 Manufactured for/ Hecho para/ Fabriqué pour Alera®/ Essendant Co.,  
 One Parkway North, Deerfield, IL 60015 © 2017 Essendant Co.  
 Made in/ Hecho en/ Fabriqué en China  
 Product support and parts: 1-800-733-4000  
 Ayuda del producto y partes / Support technique et pieces



# OPERATING INSTRUCTIONS

ALE-GM4136/ALE-GM4146

## A. Seat height adjustment

To raise the seat height, stand up from the chair while lifting the lever (A) under the right side of the seat. To lower the seat height, lift the lever (A) while sitting in the chair.

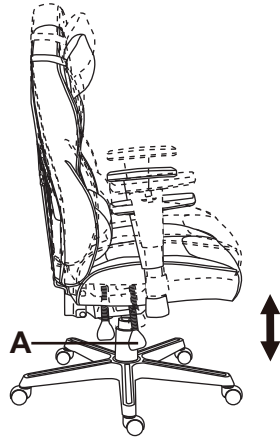

## B. Back Angle

Lift the lever (B) to adjust the angle of the back. Release the lever (B) to lock the back angle.

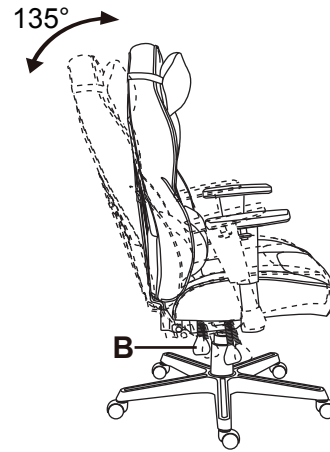

## C. Arm Adjustment

Raise or lower to support your forearms.





# INSTRUCCIONES DE INSTALACIÓN

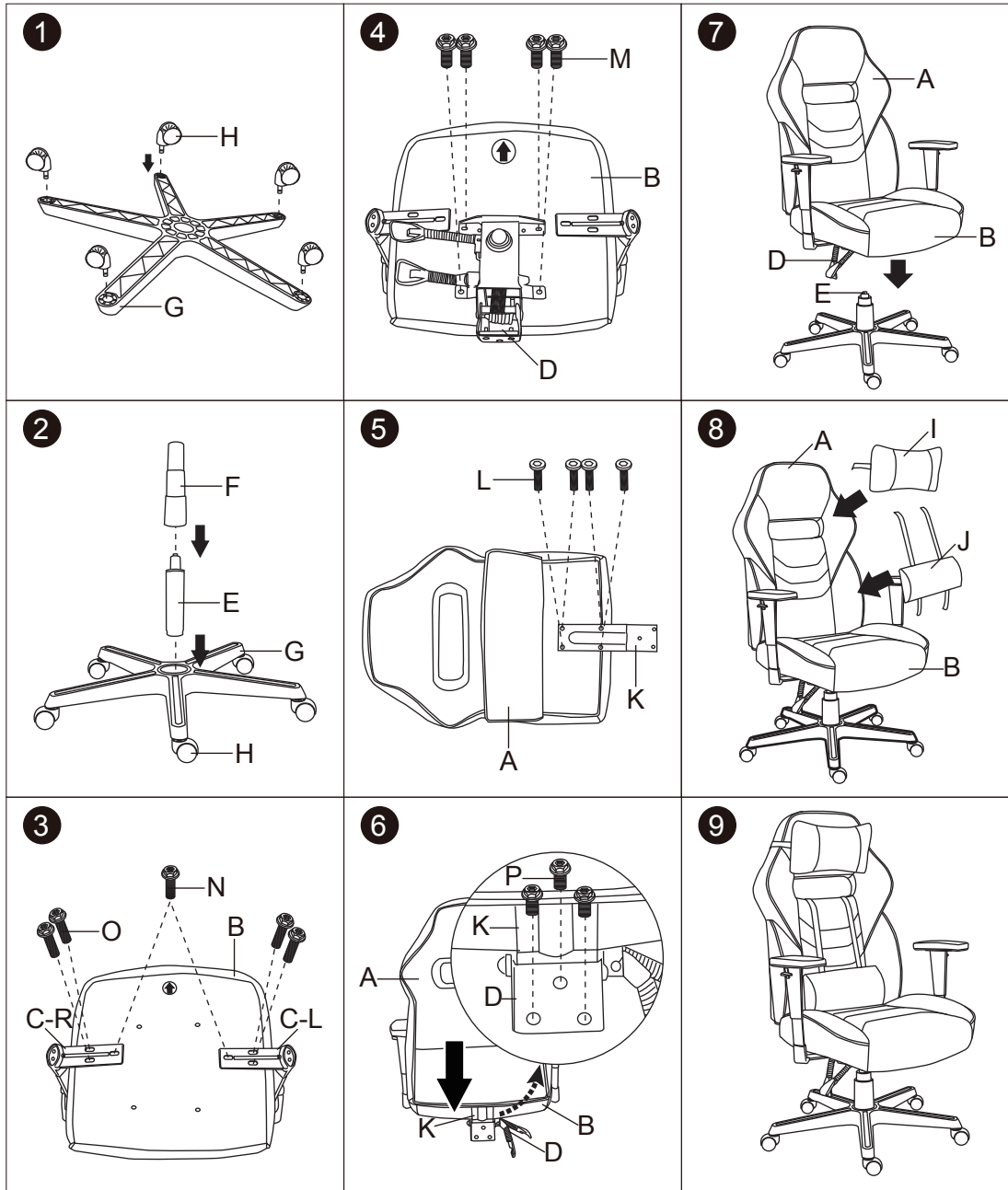

<b>A.</b>  1PZ	<b>G.</b>  1PZ	<b>M.</b>  4PZS
<b>B.</b>  1PZ	<b>H.</b>  5PZS	<b>N.</b>  2PZS
<b>C(-L/-R).</b>  1PZ	<b>I.</b>  1PZ	<b>O.</b>  4PZS
<b>D.</b>  1PZ	<b>J.</b>  1PZ	<b>P.</b>  3PZS
<b>E.</b>  1PZ	<b>K.</b>  1PZ	<b>Q.</b>  1PZ
<b>F.</b>  1PZ	<b>L.</b>  4PZS	

Modelo: ALE-GM4136/ALE-GM4146  
 Manufactured for/ Hecho para/ Fabriqué pour Alera®/ Essendant Co.,  
 One Parkway North, Deerfield, IL 60015 © 2017 Essendant Co.  
 Made in/ Hecho en/ Fabriqué en China  
 Product support and parts: 1-800-733-4000  
 Ayuda del producto y partes / Support technique et pieces



# INSTRUCCIONES OPERATIVAS

ALE-GM4136/ALE-GM4146

## A. Ajuste de la altura del asiento

Para subir la altura del asiento, levantarse de la silla mientras se sube el nivel (A) debajo del lado derecho del asiento. Para bajar el asiento, levantar el nivel (A) mientras se está sentado en la silla.

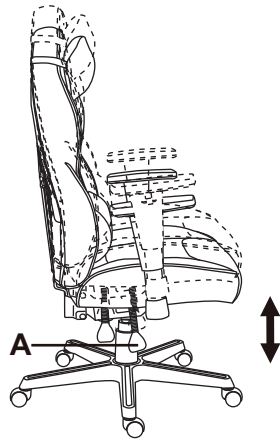

## B. INCLINACIÓN POSTERIOR

Levante la palanca para ajustar el ángulo de la parte posterior. Suelte la palanca para bloquear el ángulo posterior.

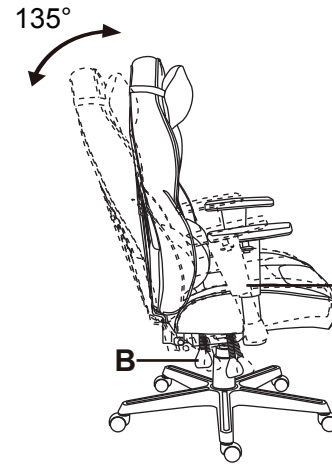

## C. Ajuste Del Brazo









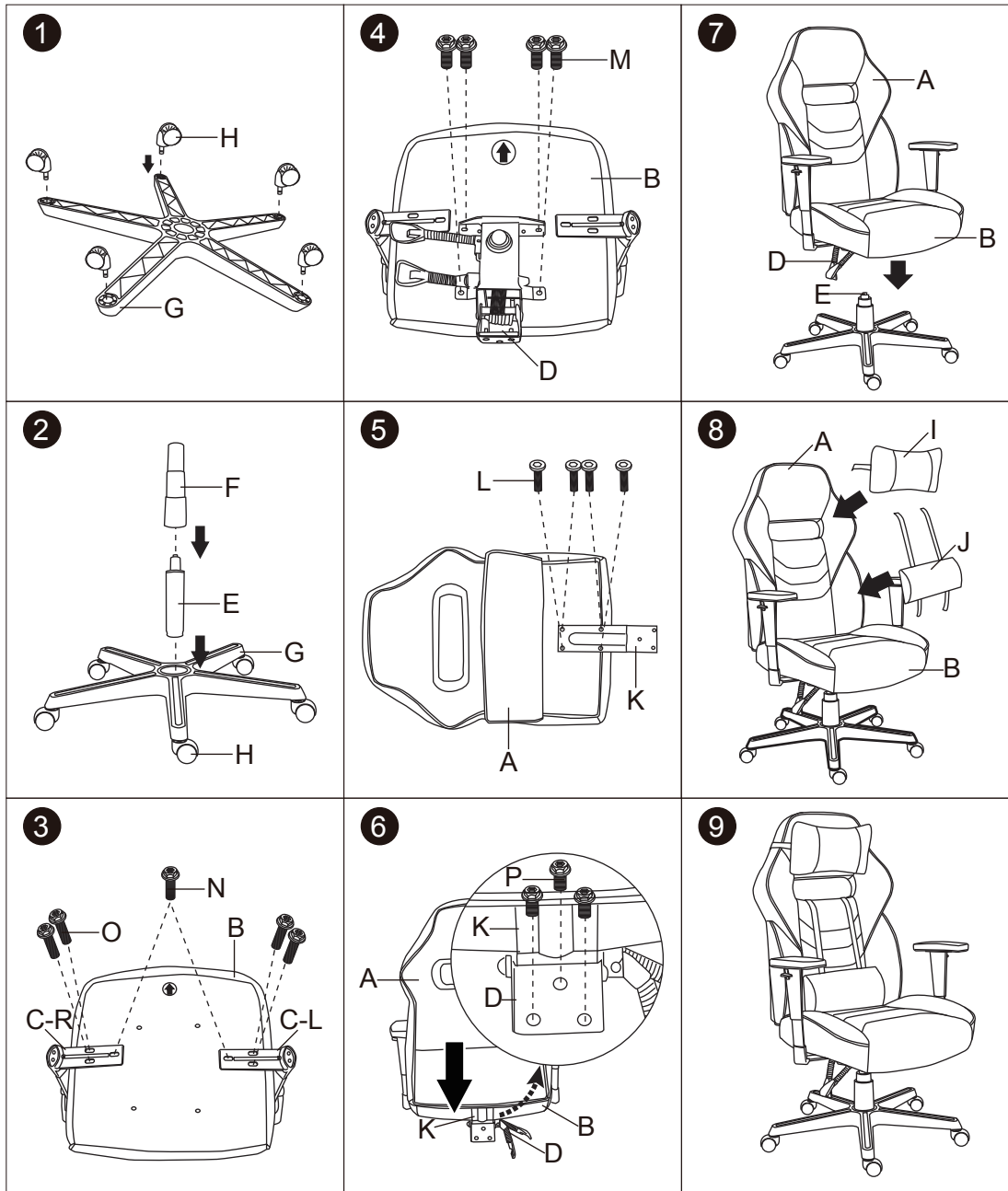







Levant o baje apoyar sus antebrazos

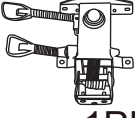

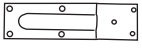

# INSTRUCTIONS DE MONTAGE



A.  1PIECE	G.  1PIECE	M.  4PIECES
B.  1PIECE	H.  5PIECES	N.  2PIECES
C(-L/-R).  1PIECE	I.  1PIECE	O.  4PIECES
D.  1PIECE	J.  1PIECE	P.  3PIECES
E.  1PIECE	K.  1PIECE	Q.  1PIECE
F.  1PIECE	L.  4PIECES	

Modèle: ALE-GM4136/ALE-GM4146

Manufactured for/ Hecho para/ Fabriqué pour Alera®/ Essendant Co.,  
One Parkway North, Deerfield, IL 60015 © 2017 Essendant Co.

Made in/ Hecho en/ Fabriqué en China

Product support and parts: 1-800-733-4000

Ayuda del producto y partes / Support technique et pieces

10-017/1



# MODE D'EMPLOI

## ALE-GM4136/ALE-GM4146

### A. Réglage de la hauteur du siège

Pour élever la hauteur du siège, se lever de la chaise tout en soulevant le levier (A) sous le côté droit du siège. Pour abaisser la hauteur du siège, soulevez le levier (A) en position assise sur la chaise.

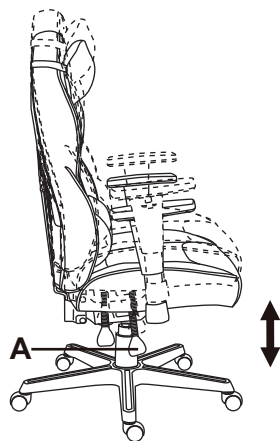

### B. INCLINAISON ARRIÈRE

Soulevez le levier pour régler l'angle de l'arrière. Relâchez le levier pour verrouiller l'angle arrière.

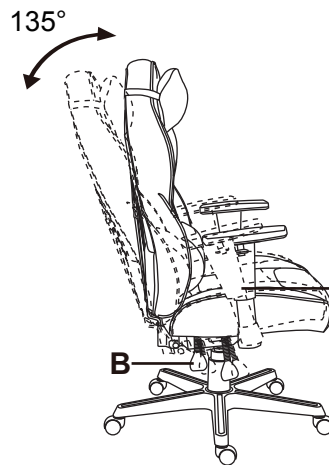

### C. Ajustement Arm

Relevez ou baissez supporter vos avant-bras.

